



# Driving the Future of E-Mobility with Power Conversion and Battery Testing

# Introduction

The electric vehicle (EV) technology ecosystem is gaining momentum as automakers begin investing in technologies that will move the sector forward. Consumer concern over climate change, along with government energy policies and incentives will also drive technology innovation in the EV space globally.

In a survey by Keysight Technologies, automakers ranked electric vehicle (EV) technologies, including inverter design, battery performance, charging, and cell formation as among their top technology investments (see Figure 1).

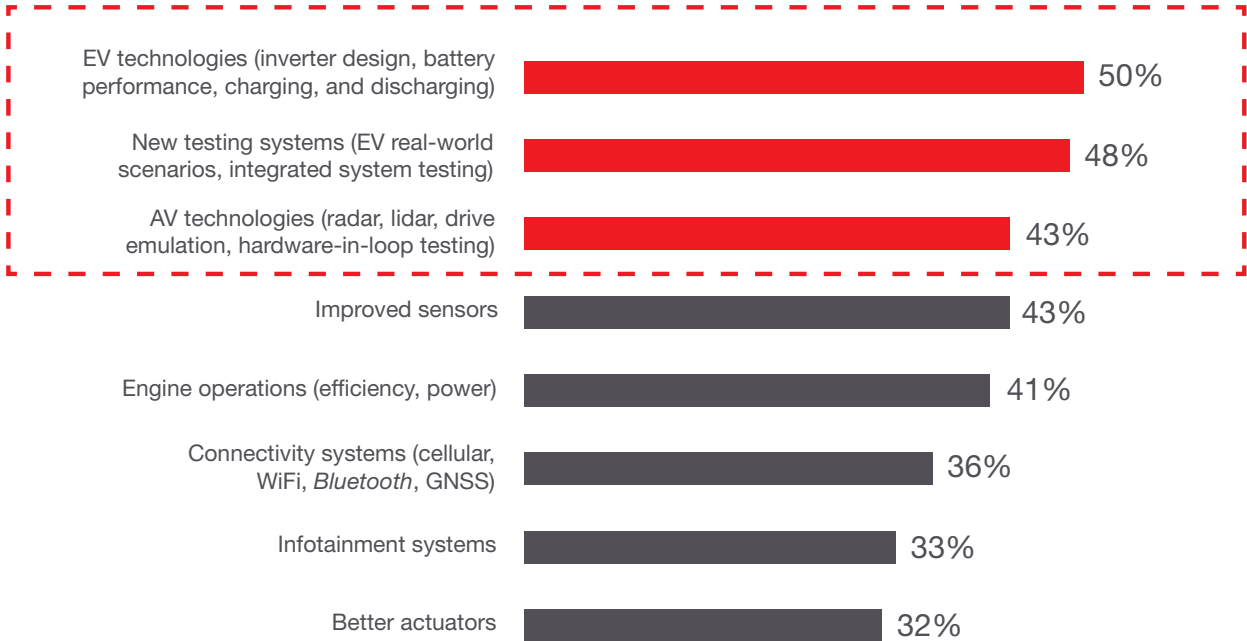

Figure 1. Leading automotive technology investments by automakers

E-mobility innovations are evolving at a rapid pace. These innovations include smart inverters that can help integrate solar energy and other distributed energy resources (DERs) into the electric grid, fast-charging EV supply equipment (EVSE), and increasingly potent battery cells that enable range assurance. Technologies like these and more are helping drive the adoption of EVs.

# Under the Hood: Trends and New Test Challenges

The EV ecosystem consists of myriad electronic devices and sub-systems:

- Power devices
- Power converters
- Li-ion (lithium-ion) cells
- EV-grid interfaces

With shorter product development cycles and various power configurations (see Figure 2), new criteria monitor the EV industry for the safety, performance, and business viability of these sub-systems. Rigorous design verification and testing — from product development to high-volume production — are requirements.

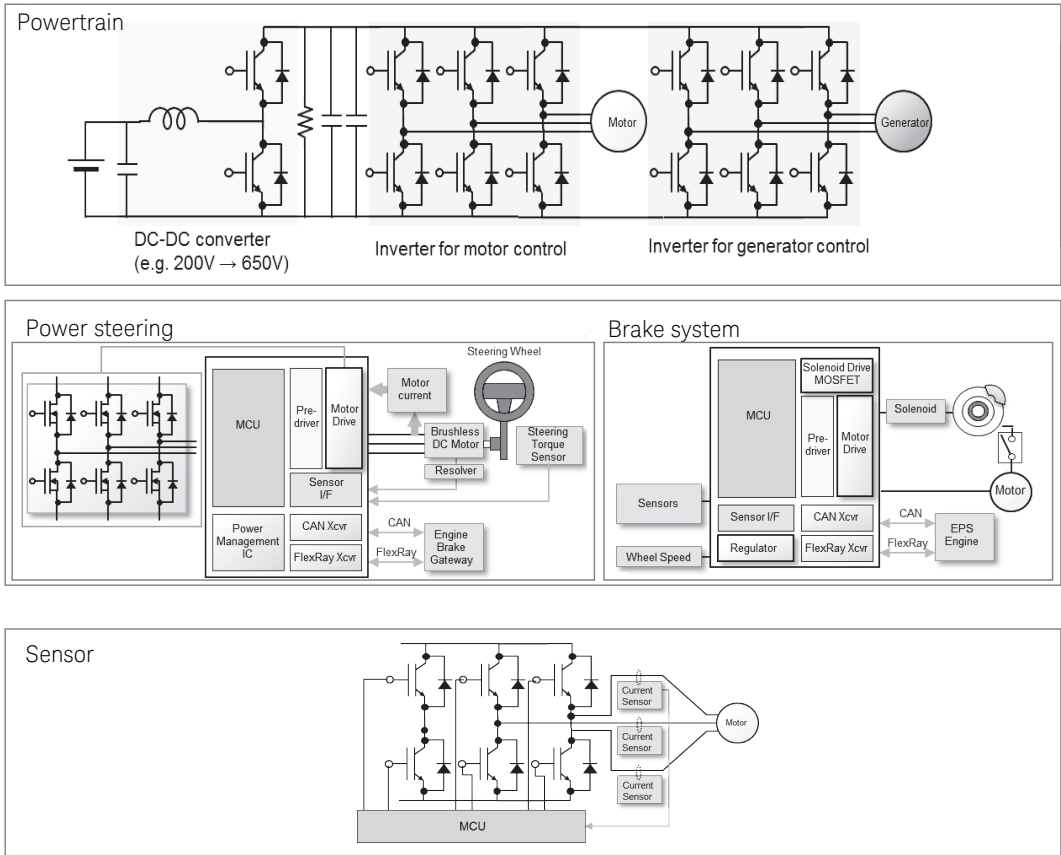

Figure 2. Electrification of vehicle sub-systems

# Power Devices – SiC and GaN Offer Benefits and Challenges

New EVs require much higher power, driving designers to adopt wideband gap (WBG) silicon carbide (SiC) and gallium nitride-based (GaN) devices to convert power in various parts of the EV (Figure 3).

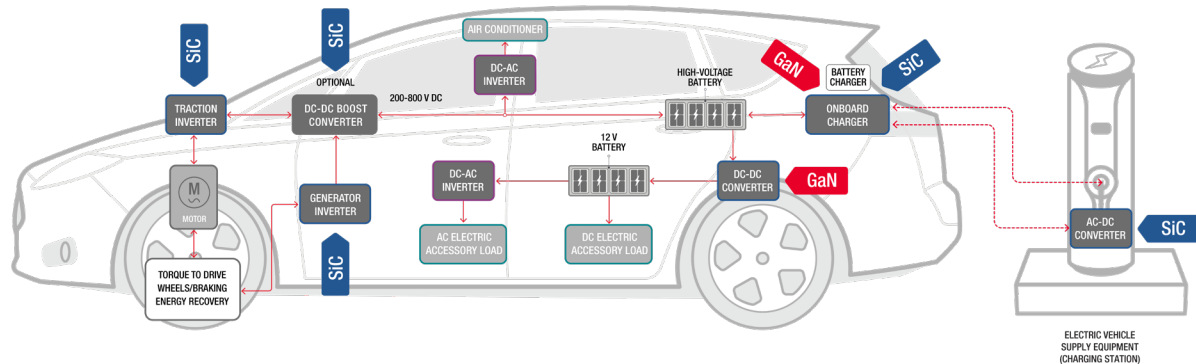

Figure 3. SiC and GaN wideband gap devices enable high-power conversion applications in the modern electric vehicle

WBG semiconductors offer several benefits like much faster switching frequencies with higher voltage and thermal operations. However, switching losses tend to increase with frequency, reducing the efficiency of the power converter. Apart from measuring and characterizing conduction losses, power converter designers must consider dynamic characterization of WBG power semiconductors to better understand switching losses.

**Double-pulse test (DPT)** is the de facto dynamic measurement approach for determining WBG switching losses. Designers must ensure their products conform to industry standards, such as those set by the JEDEC Solid State Technology Association (formerly known as the Joint Electron Device Engineering Council), a global leader in developing open standards and publications for the microelectronics industry.

# Power Conversion: Efficiency and Safety are Key to Success

A tremendous amount of power conversion takes place within the EV, whether it is a fully electric, strong hybrid, or mild hybrid vehicle. Figure 4 shows a simplified block diagram of a couple of these electrified vehicle architectures. For the strong (or parallel) hybrid and the pure EV (no combustion engine) types, a large battery powers a high voltage (HV) board net, which also powers the electric powertrain. In the mild hybrid, the engine and battery both contribute to the powertrain, and the battery is used for regenerative braking and charging the 12V battery.

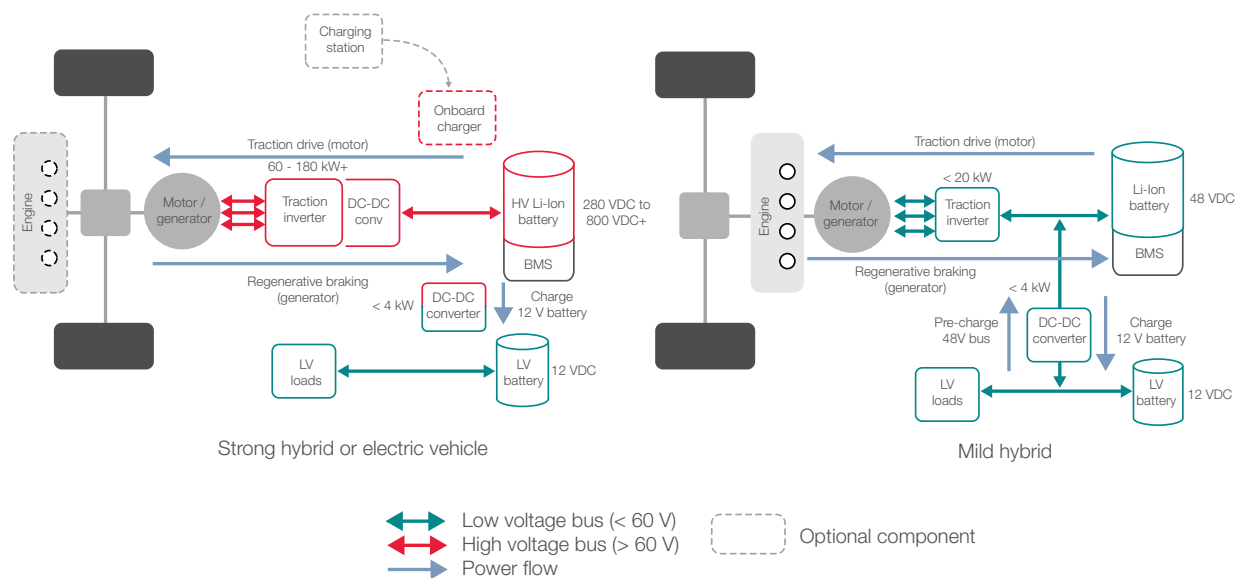

**Figure 4.** Fully electric, strong hybrid, and mild hybrid EV architectures

Power levels of the inverter and motor / generator range from ~50 kW up, to and over 180 kW. Along with the large Li-Ion battery, it takes a significant investment to develop these architectures. Most of the components support bidirectional power flow. Power flows from the battery to the inverter / motor to propel the vehicle. When decelerating, regenerative braking occurs. The vehicle's momentum turns the generator, driving power back through the inverter to charge the battery.

In the mild hybrid, the motor / generator, inverter, DC-DC converter, and battery are all bidirectional. The inverter and motor are not large enough to drive the vehicle by themselves (as in the case of a hybrid EV or EV), but they supplement the engine power during acceleration and recharge the battery during deceleration. This technology also uses a 48 V board net to reduce safety concerns and cost.

Since DC-DC converters operate well over the 60 V safety limit, designers, technicians, and operators need to be careful when testing a converter. Special safety mechanisms (the NFPA 79 safety standards for industrial machinery) must be in place throughout the design and test process. Safety standards need a “redundant system,” where any failure of the test system would not expose the operator to high voltage shocks. These safety systems are often custom-designed and costly to deploy.

To reduce the cost pressures on designers and manufacturers, Keysight developed a robust commercial **off-the-shelf regenerative power system** with integrated safety features that protect people and devices under test. In addition, the system channels energy from the regenerative phase of the test back onto the grid cleanly, a process that saves utilities the cost of energy consumption and cooling.

## Cells and Batteries: The Heart of E-Mobility

One of the biggest consumer concerns around EVs is range anxiety, or whether the vehicle will simply run out of battery power without adequate warning. Improvements in battery technology are helping to assuage the concern of being stuck in the middle of nowhere with a dead battery.

EV batteries have come a long way in more than a decade when they supplied only 50-60 miles per full charge, often with limited horsepower. Now, an average-priced EV offers a range of over 250 miles per full charge.

EV manufacturers and providers in the battery supply chain continue to look for ways to test the performance of each cell. For example, they are studying cell self-discharge, a phenomenon that erodes overall battery performance.

# Cell Self-Discharge

Cell self-discharge reduces a battery's stored charge with no connection between the electrodes. Self-discharge decreases the shelf-life of batteries and causes them to initially have less than a full charge when batteries are in use.

To detect higher-than-normal self-discharge in Li-Ion cells, developers and manufacturers traditionally rely on measuring the drop of a cell's open-circuit voltage (OCV) over a period of several weeks or longer to achieve robust validation. The long wait time during development results in lost opportunities by being late to the market with new designs. The problem worsens if you must repeat self-discharge testing. In manufacturing, storing large quantities of cells for an extended time to screen them for self-discharge, adds a layer of complexity in the form of expenses, logistics, and safety issues.

Measuring a cell's self-discharge current provides an alternate means to directly determine a cell's self-discharge rate. You can identify and isolate cells that exhibit excessively high self-discharge in a fraction of the time versus the traditional OCV approach. The time-savings can greatly reduce the expenses, difficulties, and potential hazards associated with storing and testing these cells in large quantities.

## Self-Discharge Measurement Solution

To address the needs of cell developers and manufacturers, Keysight came up with a revolutionary **Li-ion cell self-discharge measurement solution** that reduces the time it takes to measure cell self-discharge current (see Figure 5). For smaller cells like cylindrical 18650 or 21700 cells, testing indicates that you can quickly measure stable self-discharge current in as little as 30 minutes to 2 hours, depending on the cell characteristics. And for larger capacity pouch cells (e.g., 10-60 Ah), the measurements will take as little as 1 to 4 hours.

The time-savings represents a significant improvement compared to waiting weeks or months for the cell OCV to change enough to determine cell quality. It also helps shorten the test cycle and improve time to market.

As research and development intensifies into understanding how cells and batteries perform in varying conditions, the promise of longer battery life draws closer.

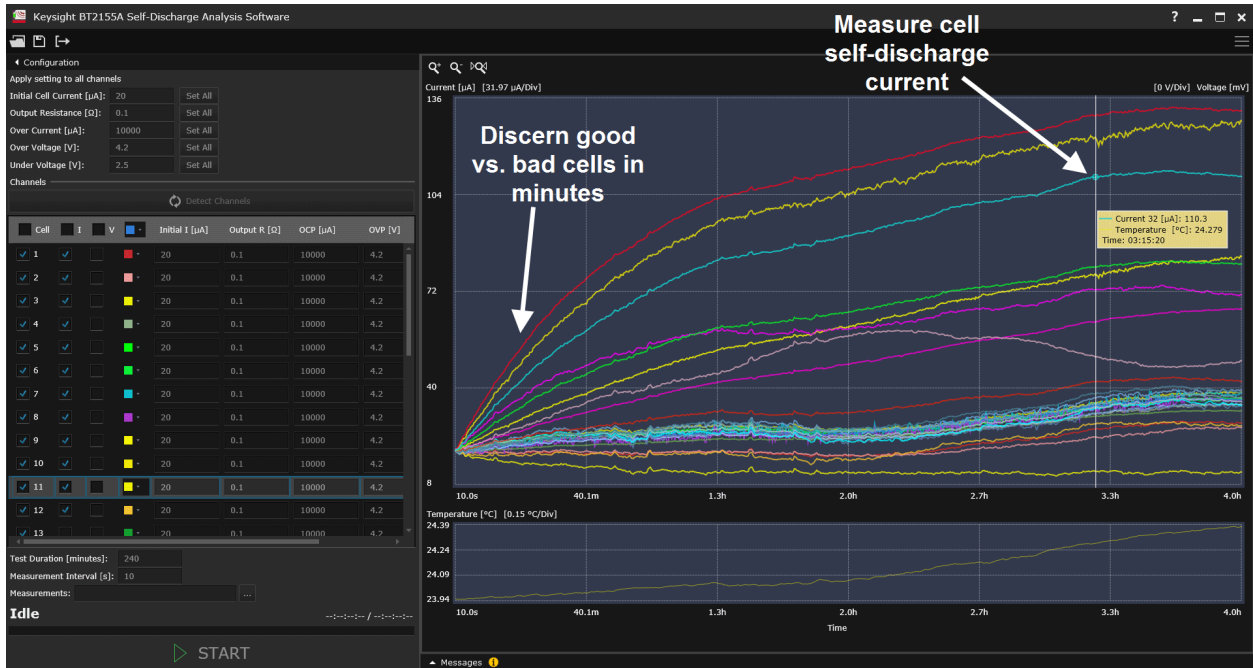

**Figure 5.** Keysight’s potentiostatic cell self-discharge measurement solution reduces the time taken to study how Li-ion cells undergo self-discharge.

As Li-ion cells get assembled into modules and packs for the EV, it’s essential to ensure the assemblies and interconnections work according to specifications. These are some tests that need to be done to verify the battery’s performance at the cell, module, and pack levels:

- Record different temperatures to investigate the reciprocal electrical and thermal influence of the cells.
- Check the mechanical connections and the performance of the module.
- Communicate with the vehicles’ battery management system (BMS).

The modern battery test laboratory is also benefiting from **new automated lab operations software** which can vastly increase productivity by enabling test and human resources planning, and data visibility on the thousands of devices under test.



# EV-to-Grid Communication

The EV connects to and must work cohesively with the electric grid. Charging stations, home energy management systems, microgrids, and smart grids each contribute a vital role in developing a more sustainable energy future.

Demand for faster and higher-capacity charging stations is driving innovative methods to ensure charging interoperability between the various EV and EVSE makes and models. EV and EVSE manufacturers use emulators that can replace actual vehicles or charging equipment to help test their products against different specifications. Figure 6 illustrates one such use case where a [Keysight Scienlab Charging Discovery System](#) emulates, or assumes the role of a charging station. A [Keysight Scienlab Regenerative 3-Phase AC Emulator](#) provides regenerative bidirectional power, and does not require a costly transformer in the test setup.



**Figure 6.** The electric car (above left) can be tested to ensure it works with different types of charging stations simply by using an emulator (middle) and a regenerative bidirectional power supply (right).

# Sustainable Energy Ecosystem

No single test technology can address the emerging design and verification challenges of the wide range of applications, environments, and requirements in this booming e-mobility ecosystem. Newer and better electric drivetrains will become available to satisfy both consumer demands and regulatory criteria for a lower carbon footprint and extended ranges.

The future will see exciting innovations to support a more sustainable energy ecosystem via better e-mobility technology. Keysight Technologies provides the depth and breadth of test and measurement solutions to address your unique design and test challenges in the e-mobility ecosystem.

Please visit [www.keysight.com/find/e-mobility](http://www.keysight.com/find/e-mobility) for more information.